

FD FINGER CHUCK

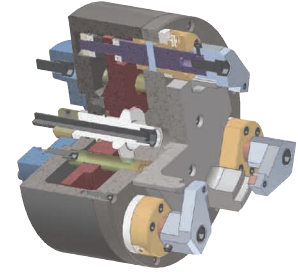

The floating design allows the chucks' swinging fingers to adjust to the shape of the workpiece preventing workpiece deformations.

The FD chuck is ideal for gripping workpieces that are impossible to grip from the inner and outer diameter or where deformations are likely to occur.

The FD chuck can be easily manipulated for 2-jaw, 3-jaw, and 4-jaw applications.

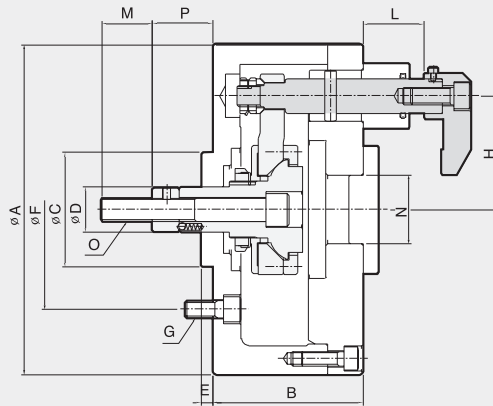
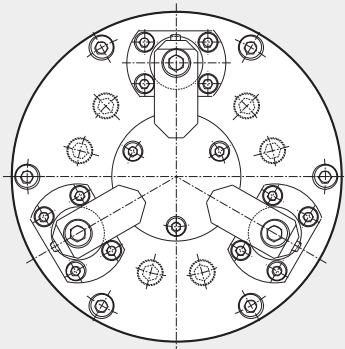

Dimensions

	A	B	C(h ⁷)	D	E	F	G	H	Lmax.	Lmin.	M	N	O	Pmax.	Pmin.
FD-06	165	75	60	35	7	104.8	M10	55	54	30	36	40	M16	44	30
FD-08	210	85	80	42	7	133.4	M12	75	59	35	36	45	M20	50	35
FD-10	254	95	120	52	7	171.4	M16	95	72	40	46	55	M24	60	40
FD-12	304	110	120	52	7	171.4	M16	120	72	45	46	55	M24	60	40
FD-15	381	125	150	55	7	230	M20	155	84	50	50	60	M27	75	50
FD-18	457	140	150	55	7	230	M20	192	84	50	50	60	M27	75	50

Specifications

	Clamping Force (kgf)	Max. Drawbar Pull (kgf)	Jaw Compensating mm (dia)	Plunger Stroke (mm)	Chucking Diameter (mm)		Max. Speed (r.m.p)	Weight (kg)	GD ² (kgf·m ²)
					Max	Min			
FD-06	1400	1800	2	14	75	30	3500	9	0.12
FD-08	2100	2700	2	15	110	50	2800	18	0.41
FD-10	2800	3600	2	20	145	60	2400	30	1.05
FD-12	2800	3600	2	20	195	110	2100	41	2.17
FD-15	3600	4500	2	20	260	180	1800	73	5.65
FD-18	3600	4500	2	25	330	215	1500	102	11.6